

No.	Description	CARBON STEEL	SS 304	SS 316	Qty.
1	Body	ASTM A 216 WCB	ASTM A 351 CF8	ASTM A 351 CF8M	1
2	Cover	ASTM A 216 WCB	ASTM A 351 CF8	ASTM A 351 CF8M	1
3	Element	SS 304/SS 316	SS 304/SS 316	SS 316	1
4	Stud & Nut	ASTM A 193 / 194 Gr. B7/ 2H	ASTM A 193 / 194 Gr. B7/ 2H (Zinc Plated)	ASTM A 193 / 194 Gr. B7/ 2H (Zinc Plated)	---
5	Gasket	SS 316 SPW WITH GR FILLER	SS 316 SPW WITH GR FILLER	SS 316 SPW WITH GR FILLER	1
6	Drain Plug	ASTM A 105	ASTM A 182 F304	ASTM A 182 F316	1
7	VENT Plug	ASTM A 105	ASTM A 182 F304	ASTM A 182 F316	1
8	HANDLE	MS	SS 304	SS 316	---

### DIMENSION

SIZE		A	B	C	ØD	ØE	F	Drain 'G'	VENT 'V'	SCREEN AREA	WEIGHT kgs. Approx
INCH	NB										
1"	25	250	100	180	4"	65	150	1/2"	1/2"	306	24
2"	50	325	120	180	4"	65	160	1/2"	1/2"	327	25
3"	80	390	175	275	6"	105	250	1/2"	1/2"	903	50
4"	100	400	200	320	6"	105	290	1/2"	1/2"	1047	60
6"	150	510	200	460	10"	180	435	3/4"	3/4"	1917	90
8"	200	580	250	575	12"	200	525	3/4"	3/4"	3297	---
10"	250	650	280	850	14"	235	810	3/4"	3/4"	5676	---
12"	300	715	325	650	16"	280	600	3/4"	1"	70336	350
14"	350	830	380	960	20"	370	900	1-1/2"	1"	10456	510
16"	400	850	400	1080	20"	400	1025	1-1/2"	1"	12874	----
24"	600	1155	532	1615	32"	625	1500	2"	2"	29437	----

### TECHNICAL DATA:-

1. END FLANGE & DRILL I/A/W ASME B 16.5 150# RF.
2. WALL THICKNESS IN ACCORDANCE WITH API 600.
3. TESTING STANDARD IN ACCORDANCE WITH API 598.

\* WE ARE CONTINUOUSLY IMPROVING OUR PRODUCT.  
WE RESERVE THE RIGHT TO CHANGE DETAIL WITH OUT PRIOR NOTICE.

### NOTE:-

1. ALL DIMENSIONS ARE IN mm. IF NOT SPECIFIED.
2. M.O.C. AS PER PROCESS REQUIREMENT.

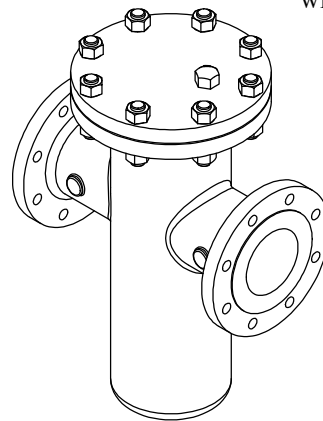

CLIENT:-		QTY.:-	
PROJECT :-		W.O.NO:-	
SCALE :- NTS	SHEET :-	DRAWING No.	REV.
FILE :-	DATE :- 14/10/2017	AFS-2536-150# STR	00
TITLE :- G.A. DRG FOR BUCKET TYPE STRAINER 150#		PROJECTION:-	
 <a href="http://www.strainersindia.com">www.strainersindia.com</a>	PLOT NO-152/2 ROAD-5, G.I.D.C.KATHWADA, AHMEDABAD.	NAME	DATE
		ACAD BY GPP	14/10/17
		CHED BY GPP	14/10/17
		APPD BY APT	14/10/17